

# CIRVIBE®

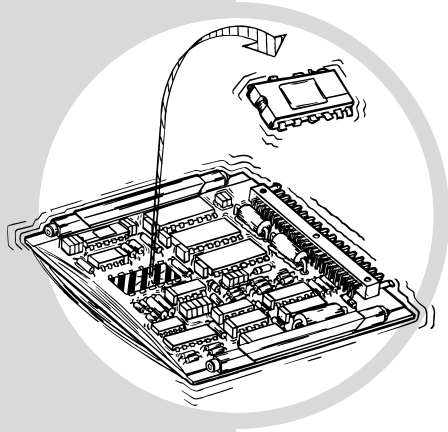

The CirVibe finite element analysis program is a package developed for use in design, test and development of reliable electronics. Automated model generation, modal analysis, detailed component stress calculations and relative fatigue evaluations are performed from simple geometric descriptions of the hardware. CirVibe methods are specially developed to provide product understanding while meeting demanding product development schedules.

CirVibe was developed for establishing, evaluating and optimizing environmental vibration stress screens for assurance of quality of components, PWAs and electronic assemblies. However, its ease of use makes it an ideal tool for all stages of the design and development process including design ruggedization. CirVibe performs detailed Finite Element Analysis (FEA), but is not a typical FEA program. Methods used in CirVibe were developed by a team of engineers including test, analysis, reliability and production specialists, with the primary goal of product understanding. FEA model generation is highly automated. Automated fatigue damage calculations provide an evaluation of component position and support conditions impact on life capabilities.

## Model Generation

Prior to CirVibe availability, the complexity of models required for life calculations of electronics made detailed finite element cost prohibitive for most organizations. Only large corporations with the appropriate staff were able to perform analyses, and then only for large volume production or expensive hardware production. CirVibe places full analysis capabilities within the reach of any electronics designer or manufacturer. CirVibe is based on proven computer-aided finite element methods, automatically generating extensive detail internally from simplified physical descriptions.

A full model can therefore be generated and analyzed in a small fraction of the time required to develop models for general finite element analysis packages. Its highly automated pre- and post-processors eliminate the need for a user to be a FEA specialist, yet FEA specialists can use CirVibe for time saving advantages.

## Analysis Speed

The equation solver has been optimized for expected configurations and offers significant time savings over general analysis packages. Time is spent evaluating and applying results, rather than spent with input detail and error chasing. The ease of analysis permits evaluation of parameters, support modes, and component position for developing optimum screens or for obtaining maximum life when used during the design process. Since actual test data can be entered into CirVibe, fatigue damage differences due to changes in frequency or transmissibility response of test units can be easily evaluated. By concentrating on the results rather than the input detail, the user can gain an understanding of life-usage and draw on experience to optimize environmental stress screens or optimize design capabilities. The ability to rapidly analyze variations in support conditions and vibration requirements make CirVibe an ideal

tool for evaluations of Commercial Off The Shelf (COTS) hardware.

## User Interface

The CirVibe interface uses the MS Windows environment for interactive access to the program library of component types and user defined library of vibration life requirements or screens. An analysis involves a geometric description of the circuit board (length, width, thickness and cutout dimensions), weight and support conditions, followed by positioning of component types and a selected list of requirements. Input is eased by use of a digitizer or formatted files. Analysis is then initiated, first performing a modal analysis, detailed stress analysis, and finally a fatigue damage assessment for each component based on maximum leadwire stress.

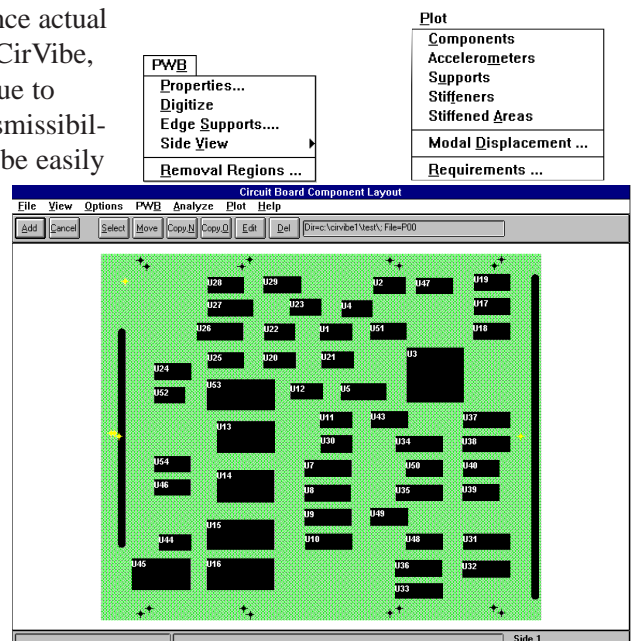

## Input

The analysis requires simple input:

- Board shape and component layout, created by interface to CAD or entered manually
- Component type library
- Additional structural parameters such as support location and types, stiffeners, and vibration requirements

## Output

- Natural frequencies and displacement mode shapes
- Relative life capabilities - ranked within each component type

## Uses

- Calculation of fatigue life of electronics exposed to accelerated life vibration testing
- Design and development of electronic hardware
- Development and optimization of production environmental stress screen vibration
- Virtual qualification of alternate designs
- Damage evaluation of Step Stress Testing, including nonlinear stepped response
- ISO 9000 quality control tracking and record keeping

## Required Configuration

- High Speed Personal Computer
- 256 MB RAM
- 2 GB available hard drive space
- CD-ROM Drive
- Windows 9x, Windows NT or Windows 2000
- Parallel Port

CirVibe is a trademark of Cirvibe, Inc.

Windows is a trademark of Microsoft Corporation.

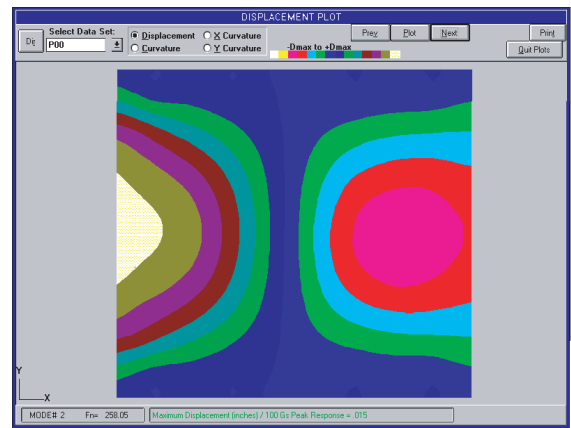

Modal Displacement Contour Plots

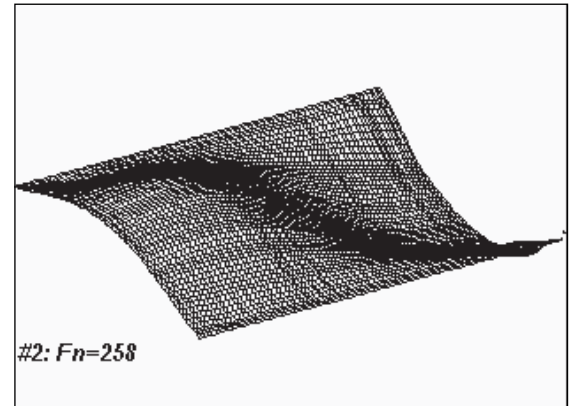

Modal Displacement Animations

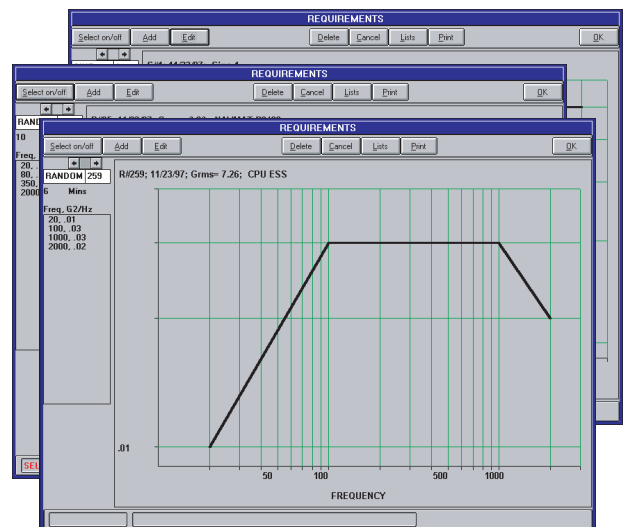

User Defined Requirements or Screens

## CIRVIBE®

CirVibe, Inc.  
P.O. Box 47394  
Plymouth, MN 55447  
(763) 559-5166

<http://www.cirvibe.com/>